

Jabra

BT530

USER MANUAL

A BRAND BY

 Netcom

ENGLISH

THANK YOU.....	2
ABOUT YOUR JABRA BT530	2
WHAT YOUR HEADSET DOES.....	3
GETTING STARTED	4
CHARGE YOUR HEADSET.....	4
TURNING YOUR HEADSET ON AND OFF	5
PAIRING IT WITH YOUR PHONE.....	5
WEARING STYLE	6
HOW TO	6
WHAT THE LIGHTS MEAN	8
LISTENING TO MUSIC USING THE JABRA BT530.....	9
USING BT530 WITH TWO MOBILE PHONES	9
USING A JABRA BLUETOOTH HUB.....	9
TROUBLESHOOTING & FAQ	10
NEED MORE HELP?.....	11
TAKING CARE OF YOUR HEADSET	11
WARNING!	11
WARRANTY	13
CERTIFICATION AND SAFETY APPROVALS.....	15
GLOSSARY	16

THANK YOU

Thank you for purchasing the Jabra BT530 Bluetooth® headset. We hope you enjoy it! This instruction manual will get you started and ready to make the most of your headset.

ABOUT YOUR JABRA BT530

- 1 Answer/end button**
- 2 On/off button**
- 3 LED light**
- 4 Charging socket**
- 5 Volume up/volume down**
- 6 Microphones**
- 7 Ear hook**
- 8 Ear gels**

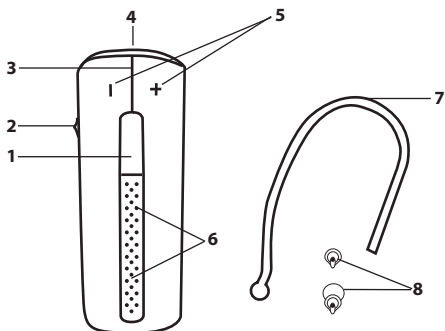

WHAT YOUR HEADSET DOES

Your Jabra BT530 lets you do all this:

- Answer calls
- End calls
- Reject calls*
- Voice dialing*
- Last number redialing*
- Call waiting*
- Put call on hold*
- Mute
- Multi-point - being connected to two Bluetooth devices at the same time
- Play music*

Specifications

- Talk time up to 4 hours/standby time up to 250 hours
- Rechargeable battery with charging option from AC power supply, PC via USB cable or car charger (not included)
- Multi-colored light for status and battery indicator
- Quiet mode – turns light off after one minute
- Size: L 48 mm x W 18mm x D 12,5 mm
- Weight: 10 grams
- Dual Microphone solution for Noise Blackout™
- Digital sound enhancement via DSP technology
- Noise reduction on transmitted and received audio
- Noise dependent volume control*
- Automatic volume adjustment on receive audio
- Acoustic shock protection
- Qualified for Bluetooth Specification version 2.0 + EDR (enhanced data rate), supporting Headset and Hands-free Profiles for phone conversations and Advanced Audio Distribution Profile (A2DP) for streaming music
- e-SCO for enhanced audio quality
- 128 bit encryption
- Operating range up to 10 meters (approx. 33 feet)

GETTING STARTED

You should follow three steps before using your headset

- 1. Charge your headset**
- 2. Activate Bluetooth on your mobile phone (refer to the manual for your Mobile phone)**
- 3. Pair your headset to your mobile phone**

The Jabra BT530 is easy to operate. The answer/end button on the headset performs different functions depending on how long you press it.

Instruction	Duration of press
Tap	Press briefly
Double Tap	2 quickly repeated taps
Press	Approx: 1 second
Press and hold	Approx: 5 seconds

CHARGE YOUR HEADSET

Make sure that your headset is fully charged before you start using it (duration app. 2 hours). Use the AC power supply to charge from a power socket. When the light indicator (LED) has a solid LED light, your headset is charging. When the LED light is solid green your headset is fully charged.

Use only the charger provided in the box - do not use chargers from any other devices as this may damage your headset.

What you see	Charge Level
Solid Red	Less than 70% charged
Solid Yellow	Between 70% and fully charged
Solid Green	Fully charged

Please note: The lifetime of the battery will be significantly reduced if your device is left uncharged for a long period. We therefore recommend that you recharge your device at least once a month.

TURNING YOUR HEADSET ON AND OFF

- Slide the on/off button forward on the side of the headset to turn on the headset. The LED will flash green for a second when the headset is on.
- Slide the on/off button backward to turn off the headset.

PAIRING IT WITH YOUR PHONE

Headsets are connected to phones using a procedure called 'pairing'. By following a few simple steps, a phone can be paired with a headset in a matter of minutes.

1. Put the headset in pairing mode

- When you turn on your Jabra BT530 for the first time, the headset will automatically start up in pairing mode – i.e. it is discoverable for your phone. When the headset is in pairing mode the LED is constantly lit.

2. Set your Bluetooth phone to 'discover' the Jabra BT530

- Follow your phone's instruction guide. First make sure that Bluetooth is activated on your mobile phone. Then set your phone to discover the headset. This usually involves going to a 'setup,' 'connect' or 'Bluetooth' menu on your phone and selecting the option to 'discover' or 'add' a Bluetooth device.*

3. Your phone will find the Jabra BT530

- Your phone will find the headset under name "Jabra BT530". Your phone then asks if you want to pair with the headset. Accept by pressing 'Yes' or 'OK' on the phone and confirm with the passkey or PIN = 0000 (4 zeros). Your phone will confirm when pairing is complete.



In case of unsuccessful pairing, put the Jabra BT530 into pairing mode manually. Make sure the headset is on. Press and hold the answer/end button for approximately 5 seconds until the LED has a constant light. Keep holding down the button until light is constant.

WEARING STYLE

The Jabra BT530 is ready to be worn, but can be used with or without the ear hook. The ear hook can be removed and the headset can be used with the Ultimate Comfort Ear gels.

The Ultimate Comfort Ear gels can be used for both left and right wearing. The BT530 comes fitted with a medium sized ear gel, but it can be replaced by a small or large one. You can also twist the ear gel slightly to optimize the fit and comfort. For optimal performance, wear the Jabra BT530 and your mobile phone on the same side of your body or within line of sight. In general, you will get better performance when there are no obstructions between your headset and your mobile phone.

HOW TO

Answer a call

- Tap the answer/end button on your headset to answer a call.

End a call

- Tap the answer/end button to end an active call.

Reject a call*

- Press the answer/end button when the phone rings to reject an incoming call. Depending on your phone settings, the person who called you will either be forwarded to your voice mail or will hear a busy signal.

Make a call

- When you make a call from your mobile phone, the call will (subject to phone settings) automatically transfer to your headset. If your phone does not allow this feature, tap on the Jabra BT530's answer/end button to transfer the call to the headset.

Activate voice dialing*

- Press the answer/end button. For best results, record the voice dialing tag through your headset. Please consult your phone's user manual for more information about using this feature.

Redial last number*

- Double tap the answer/end button when the headset is on and not used.

Adjust sound and volume*

- Tap the volume up or down to adjust the volume.

Mute/un-mute

- To mute, press both volume up and down at the same time. A low beep alert plays during a muted call.
- To un-mute, tap either of the volume buttons.

Call waiting and placing a call on hold*

- This lets you put a call on hold during a conversation and answer a waiting call.
- Press the answer/end button once to put the active call on hold and answer the waiting call.
- Press the answer/end button to switch between the two calls.
- Tap the answer/end button to end the active conversation.

Battery indicator

- Tap one of the volume buttons to see the battery level.

What you see	Battery level/Talk time
2 Green flashes	1-4 hours talk time
2 Yellow flashes	10 min.-1 hour
2 Red flashes	10 min.

WHAT THE LIGHTS MEAN

What you see	Battery level/Talk time
Flashing blue and green light	Incoming call
Flashing blue light	Flashing every three seconds: In Standby mode and connected to mobile phone (only for 1 minute then off)
Flashing green light	Flashing every three seconds: In standby mode – not connected (only for 1 minute then off)
Flashing blue light	Flashing every second: active call (only for 30 seconds then off)
Flashing red light	Running low on battery
Flashing purple light	Flashing every seconds: Connected in A2DP streaming music (only for 30 seconds then off)
Solid blue light	In pairing mode
Solid purple light	Special music pairing mode See chapter Troubleshooting & FAQ - Frequently Asked Questions
Solid green light	Fully charged
Solid yellow light	Charging level between 70% and fully charged
Solid red light	Charging level less than 70%

LISTENING TO MUSIC USING THE JABRA BT530

Jabra BT530 is capable of streaming music over Bluetooth - either from a mobile phone or any other Bluetooth device supporting A2DP. Once you have paired your BT530 with your mobile phone or to the Bluetooth music player, use your phone or music player to play, pause, stop, skip forward and backward. When you receive a call, the music will automatically be suspended and you will be able to answer or reject a call through the headset. Once you end a call, the music should recommence. On some phones and music devices you may have to press 'play' to start the music again.

USING BT530 WITH TWO MOBILE PHONES

Jabra BT530 is capable of having two mobile phones (or Bluetooth devices) connected to the headset at the same time. This will give you the freedom of having only one headset to operate both your mobile phones. Please note that Last Number Redial will dial the number from the last outgoing call, independent of the mobile phone, and the Voice Dialing function will only work on the last paired mobile phone.

USING A JABRA BLUETOOTH HUB

The Jabra BT530 can be used along with the Jabra Bluetooth Hub (sold separately). This will enable you to use the headset with both your mobile phone and your office phone.

To pair the Jabra BT530 with the Jabra Bluetooth Hub

The pairing process is a little different:

1. Put your Jabra BT530 in pairing mode
2. Put the Jabra Bluetooth Hub in pairing mode.
3. Place them close together. You do not need a dedicated pin code to pair the two Jabra products.

Consult the Jabra Bluetooth Hub user manual for more information on how to connect the Bluetooth hub to your office phone. The use of the Jabra BT530 with the Jabra Bluetooth Hub is very similar to using the headset with a mobile phone only. The only difference lies in the transfer of a call to the headset from the office phone.

Transfer the call to the headset

- Tap the answer/end button to transfer the call from the office phone to the headset via the Jabra Bluetooth Hub.

The answering of a call from the office phone requires a hook lifter in order to have the Jabra BT530 answer the call automatically.

TROUBLESHOOTING & FAQ

I hear crackling noises

- Bluetooth is a radio technology, which means it is sensitive to objects between the headset and the connected device. It is designed for the headset and the connected device to be used within 10 meters (33 feet) of each other, with no major objects in the way (walls, etc.).

I cannot hear anything in my headset

- Increase the volume in the headset.
- Ensure that the headset is paired to a device that is playing.
- Make sure your phone is connected to the headset by tapping the Answer/End button.

I am having pairing problems

- You may have deleted your headset pairing connection in your mobile phone. Follow the pairing instructions.

I want to reset the headset

- It is possible to reset and test the headset by 'pressing and holding' all three buttons at the same time. The red, blue and green light will light up in a white light. In this mode, the pairing list is reset, and you can test if the headset works as you will be able to hear audio in the speaker from the microphone.
- The headset will automatically turn off after approx. 10 seconds. The next time you power on, the headset will go into pairing mode as the first time you powered your new BT530 on.

Will the Jabra BT530 work with other Bluetooth equipment?

- The Jabra BT530 is designed to work with Bluetooth mobile phones. It can also work with other Bluetooth devices that are compliant with Bluetooth version 1.1 or higher and support a headset, hands-free and/or advance audio distribution profile.

I cannot use Reject call, call on hold, Redial or voice dialling

These features are dependent on the ability of your phone to support a hands-free profile. Even if the handsfree profile is implemented reject call, call hold and voice dialling are optional features which are not supported by all devices. Please consult your device manual for details.

Please note that some features can only be operated from the primary device e.g. voice dial using Jabra BT530 with 2 mobile phones.

NEED MORE HELP?

- 1. Web:** www.jabra.com
(for the latest support info and online User Manuals)
- 2. E-mail:** support.uk@jabra.com
Information: info@jabra.com
- 3. Phone:** 0800 0327026

TAKING CARE OF YOUR HEADSET

- Always store the Jabra BT530 with the power off and safely protected
- Avoid storage at extreme temperatures (above 45°C/113°F – including direct sunlight – or below -10°C/14°F). This can shorten battery life and may affect operation. High temperatures may also degrade performance.
- Do not expose the Jabra BT530 to rain or other liquids.

WARNING!

Headsets are capable of delivering sounds at loud volumes and high pitched tones. Exposure to such sounds can result in permanent hearing loss damage. The volume level may vary based on conditions such as the phone you are using, its reception and volume settings, and the environment. Please read the safety guidelines below prior to using this headset.

Safety guidelines

1. Prior to using this product follow these steps

- Before putting on the headset, turn the volume control to its lowest level,
- Put the headset on, and then
- Slowly adjust the volume control to a comfortable level.

2. During the use of this product

- Keep the volume at the lowest level possible and avoid using the headset in noisy environments where you may be inclined to turn up the volume;
- If increased volume is necessary, adjust the volume control slowly;
and
- If you experience discomfort or ringing in your ears, immediately discontinue using the headset and consult a physician.

With continued use at high volume, your ears may become accustomed to the sound level, which may result in permanent damage to your hearing without any noticeable discomfort.

Using the headset while operating a motor vehicle, motorcycle, watercraft or bicycle may be dangerous, and is illegal in some jurisdictions. Check your local laws. Use caution while using your headset when you are engaging in any activity that requires your full attention. While engaging in any such activity, removing the headset from your ear area or turning off your headset will keep you from being distracted, so as to avoid accident or injury.

3. Keep out of reach of children:

The plastic bags the product and its parts are wrapped in are not toys for children. The bags themselves or the many small parts they contain may cause choking if ingested. Never try to dismantle the product yourself. None of the internal components can be replaced or repaired by users.

Only authorised dealers or service centres may open the product. If any parts of your product require replacement for any reason, including normal wear and tear or breakage, contact your dealer.

4. ACA TS028 – Ignition of flammable atmospheres

Do not use the Headset in environments where there is a danger of ignition of flammable gases.

WARRANTY

Limited Two (2) -Year Warranty

GN Netcom A/S, warrants this product to be free from defects in materials and workmanship (subject to the terms set forth below) for a period of two (2) year from the date of purchase ("Warranty Period"). During the Warranty Period, GN Netcom will repair or replace (at GN Netcom's discretion) this product or any defective parts ("Warranty Service"). If repair or replacement is not commercially practicable or cannot be timely made, GN Netcom may choose to refund to you the purchase price paid for the affected product. Repair or replacement under the terms of this warranty does not give right to any extension or a new beginning of the period of warranty.

Claims under the Warranty

To obtain Warranty Service, please contact the GN Netcom dealer from which you purchased this product or visit www.jabra.com for further information about customer support. You will need to return this Product to the dealer or ship it to the dealer or to GN Netcom (if so indicated on www.jabra.com) in either its original packaging or packaging affording an equal degree of protection. You will bear the cost of shipping the product to GN Netcom. If the Product is covered by the warranty, GN Netcom will bear the cost of shipping product back to you after the completion of service under this warranty. Return shipping will be charged to you for products not covered by the warranty or requiring no warranty repair.

The Following information must be presented to obtain Warranty Service: (a) the product, and (b) proof of purchase, which clearly indicates the name and address of the seller, the date of purchase and the product type, which is evidence that this product is within the Warranty Period. Please further include (c) your return address. (d) daytime telephone number, and (e) reason for return. As part of GN Netcom/Jabra's efforts to reduce environmental waste you understand that the product may consist of reconditioned equipment that contains used components, some of which have been reworked. The used components all live up to GN Netcom/Jabra's high quality standards and comply with the GN Netcom product performance and reliability specifications. You understand that replaced parts or components will become the property of GN Netcom.

Limitation of Warranty

This warranty is only valid for the original purchaser and will automatically terminate prior to expiration if this product is sold or otherwise transferred to another party. The warranty provided by GN Netcom in this statement applies only to products purchased for use, and not for resale. It does not apply to open box purchases, which are sold "as is" and without any warranty. Specifically exempt from warranty are limited-life consumable components subject to normal wear and tear, such as microphone windscreens, ear cushions, modular plugs, ear tips, decorative finishes, batteries, and other accessories. This warranty is invalid if the factory-applied serial number, date code label, or product label has been altered or removed from this product. This Warranty does not cover cosmetic damage or damage due to misuse, abuse, negligence, Acts of Nature, accident, disassembling or modification of, or to any part of, the product. This Warranty does not cover damage due to improper operation, maintenance or installation, or attempted repair by anyone other than GN Netcom or a GN Netcom dealer which is authorized to do GN Netcom warranty work. Any unauthorized repairs will void this warranty.

REPAIRS OR REPLACEMENTS AS PROVIDED UNDER THIS WARRANTY ARE THE EXCLUSIVE REMEDY OF THE CONSUMER. GN Netcom SHALL NOT BE LIABLE FOR ANY INCIDENTAL OR CONSEQUENTIAL DAMAGES FOR BREACH OF ANY EXPRESS OR IMPLIED WARRANTY ON THIS PRODUCT. EXCEPT TO THE EXTENT PROHIBITED BY LAW, THIS WARRANTY IS EXCLUSIVE AND IN LIEU OF ALL OTHER EXPRESS AND IMPLIED WARRANTIES WHATSOEVER, INCLUDING BUT NOT LIMITED TO THE WARRANTY OF MERCHANTABILITY AND FITNESS FOR A PRACTICAL PURPOSE.

NOTE! This warranty gives you specific legal rights. You may have other rights which vary from location to location. Some jurisdictions do not allow the exclusion or limitation of incidental or consequential damages or implied warranties, so the above exclusions may not apply to you. This warranty does not affect your legal (statutory) rights under your applicable national or local laws.

CERTIFICATION AND SAFETY APPROVALS

CE

This product is CE marked according to the provisions of the R & TTE Directive (99/5/EC). Hereby, GN Netcom, declares that this product is in compliance with the essential requirements and other relevant provisions of Directive 1999/5/EC.

For further information please consult <http://www.jabra.com>

Within the EU this device is intended to be used in Austria, Belgium, Bulgaria, Cyprus, Czech Republic, Denmark, Estonia, Finland, France, Germany, Greece, Hungary, Ireland, Italy, Latvia, Lithuania, Luxembourg, Malta, Poland, Portugal, Romania, Slovakia, Slovenia, Spain, Sweden, The Netherlands, United Kingdom, and within EFTA in Iceland, Norway and Switzerland.

Bluetooth

The Bluetooth® word mark and logos are owned by the Bluetooth SIG, Inc. and any use of such marks by GN Netcom is under license. Other trademarks and trade names are those of their respective owners.

GLOSSARY

- 1. Bluetooth** is a radio technology that connects devices, such as mobile phones and headsets, without wires or cords over a short distance (approx. 10 meters/33 feet). Bluetooth is safe to use. It is secure too, so once a connection has been made no-one can listen in and there is no interference from other Bluetooth devices either. Get more information at www.bluetooth.com.
- 2. Bluetooth profiles** are the different ways that Bluetooth devices communicate with other devices. Bluetooth phones support the headset profile, the hands-free profile or both. In order to support a certain profile, a phone manufacturer must implement certain mandatory features within the phone's software.
- 3. Pairing** creates a unique and encrypted link between two Bluetooth devices and lets them communicate with each other. Bluetooth devices will not work if the devices have not been paired.
- 4. Passkey or PIN** is a code that you enter on your Bluetooth enabled device (e.g. a mobile phone) to pair it with your Jabra BT530. This makes your device and the Jabra BT530 recognize each other and automatically work together.
- 5. Standby mode** is when the Jabra BT530 is passively waiting for a call. When you 'end' a call on your mobile phone, the headset goes into standby mode.



Dispose of the product according to local standards and regulations.

www.jabra.com/weee

Jabra

MADE IN CHINA



TYPE: BT530
IC: 2386C-BT530

.....
© 2008 GN Netcom A/S. All rights reserved. Jabra® is a registered trademark of GN Netcom A/S. All other trademarks included herein are the property of their respective owners. The Bluetooth® word mark and logos are owned by the Bluetooth SIG, Inc. and any use of such marks by GN Netcom A/S is under license. (Design and specifications subject to change without notice).
.....

www.jabra.com