

WHAT'S SO COOL ABOUT THE JABRA BT5020?

The Jabra BT5020 is styled for people who appreciate a discreet state-of-the-art Bluetooth headset

It's small, light and really comfortable – it can be worn on either ear thanks to the rotating earpiece

Sound quality and operation have been improved, making the headset easy to use wherever you are

The Jabra BT5020 is MultiPoint™, enabling connection to for instance both your private and professional mobile phone



Jabra
BT 5020



Comfort
for all-day
wearing

Designed
for ultimate
discreetness

Excellent
sound
quality and
easy operation

Features and specifications

- Up to 10 hours talk time and up to 300 hours standby
- MultiPoint connections
- AutoPair functionality
- Optimized wind noise reduction
- Enable/Disable vibrating alert
- Multi-colored light indicator (LED) for:
 - LED is switched off after one minute of inactivity
 - Visual alert of incoming calls for ultimate discretion
- Charging
- Battery status indicator
- Pairing
- Weighs approx. 16 g
- Optional charging from PC via USB cable
- Mute
- Answer / end call
- Voice dial*
- Last Number redial*
- Reject call*
- Call hold / Call wait*
- Bluetooth 2.0 supporting headset and hands-free profile

* device dependent

M04_BT5020_01 11/06



Freephone customer support numbers:

Denmark: 70252272
Finland: 00800 722 52272
Italy: 800 786543
Norway: 800 61272
Spain: 900 984 542
Sweden: 020792522
UK: 0800 327 026

E-mail: support.no@jabra.com
E-mail: support.no@jabra.com
E-mail: support.it@jabra.com
E-mail: support.no@jabra.com
E-mail: support.es@jabra.com
E-mail: support.no@jabra.com
E-mail: support.uk@jabra.com

Extreme comfort – Exquisite style

Jabra



Jabra BT5020



Extreme comfort – Exquisite style

Imagine a headset so comfortable that even after wearing it all day long, you can hardly feel it. And so discreet that you and those around you hardly notice it. The new Jabra BT5020 Bluetooth headset gives you that dream combination – you might even forget to take it off when you curl up in bed!

We've made the dream come true by making a headset which is small, light and comfortable. Designed for discreet style in matt black, the Jabra BT5020 packs a lot of features into its slender shape: MultiPoint connections, wind noise reduction, visual and vibrating alert of incoming calls, battery status indicator, up to 10 hours of talk time and up to 300 hours standby – an ideal mix for hard-working people.

Once again, Jabra delivers on its promise of industry-leading performance, easy operation and state-of-the-art design.

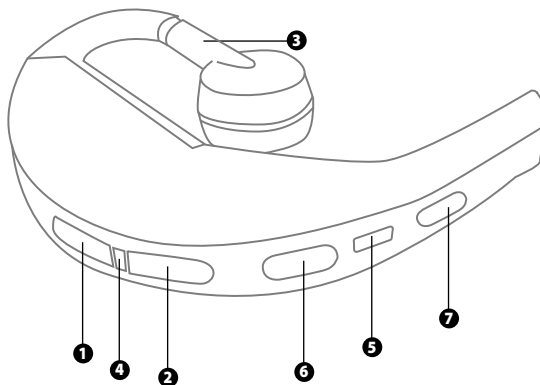

- ❶ Volume up
- ❷ Volume down
- ❸ Adjustable earhook: wear the headset on either ear
- ❹ Light indicator (LED)
- ❺ Charging socket
- ❻ On/Off/Pairing
- ❼ Answer/end button

Quick start guide

Pairing the Jabra BT5020 to a Bluetooth mobile phone:

1. Charge your Jabra BT5020 until the LED ❹ turns green (approx. 2 hours)
2. If this is the first time you are using the Jabra BT5020, it will automatically go into pairing mode otherwise please follow the next steps
3. Make sure the Jabra BT5020 is switched off ❸
4. To put the Jabra BT5020 in pairing mode, press and hold the answer/end button ❼ until the LED ❹ stops flashing and turns solid blue
5. Set your Bluetooth device to "discover" the Jabra BT5020 (see your device user guide)
6. Press Yes or OK when asked if you want to pair with the Jabra BT5020
7. Enter passkey or PIN = 0000 (4 zeros), then press Yes or OK
8. Your device will confirm when pairing is complete and the LED ❹ on your headset will flash
9. Start enjoying life hands-free!

Making a call

Just dial the number on your phone's keypad and press send. Once the call goes through it will automatically transfer to your headset (subject to phone settings).

Answering and ending a call

Tap the answer/end button ❼ on your headset to answer a call. To end your call, just tap the answer/end button. ❼

Mute an ongoing call

To mute an ongoing call, press both volume up ❶ and down ❷ at the same time. A low beep alert plays during a muted call. To disable mute, tap either of the volume buttons.

Jabra